

# **RYOBI**® OPERATOR'S MANUAL

## **10 in. (254 mm) Miter Saw**

### **Model TS1301 - Double Insulated**

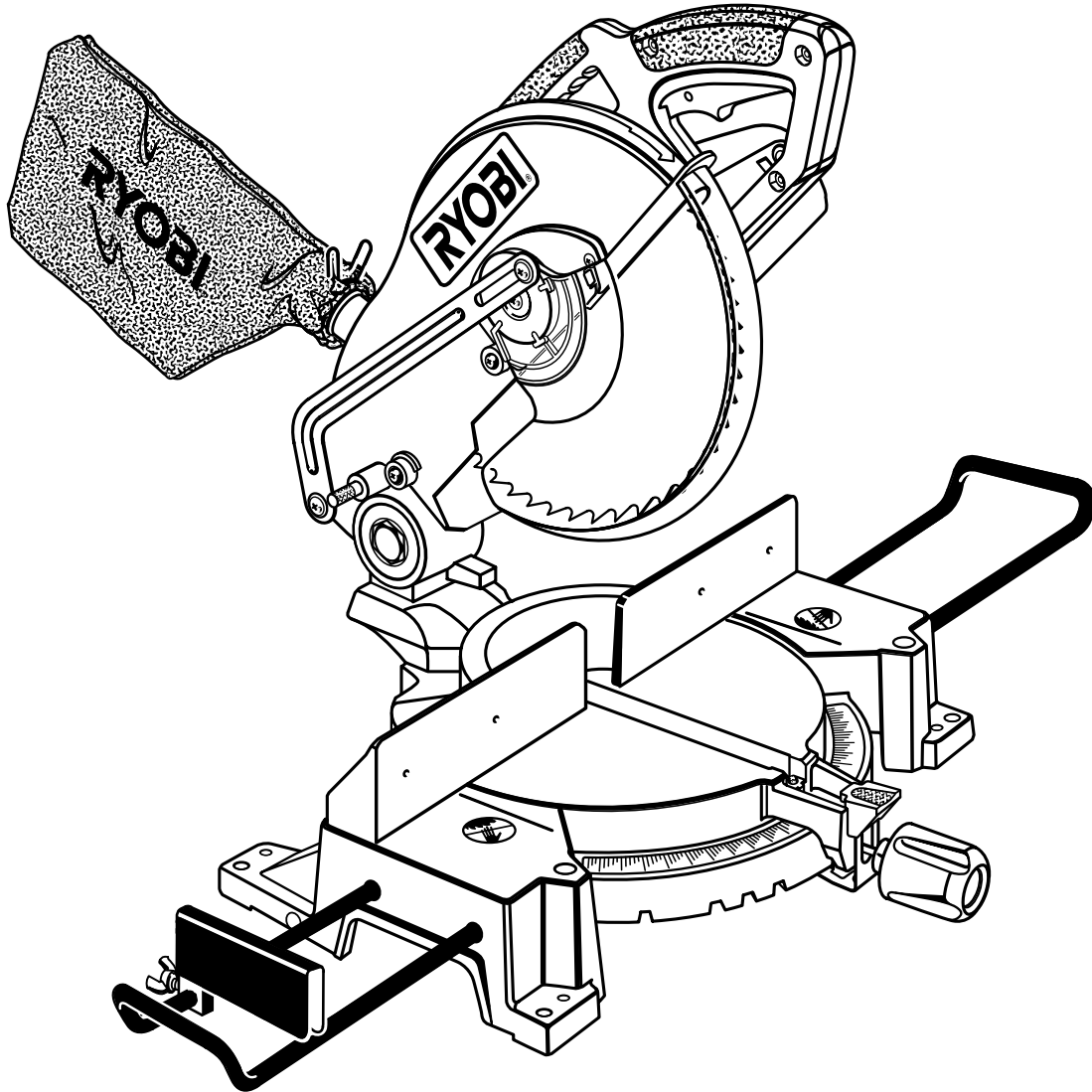

#### **THANK YOU FOR BUYING A RYOBI MITER SAW.**

Your new saw has been engineered and manufactured to Ryobi's high standards for dependability, ease of operation, and operator safety. Properly cared for, it will give you years of rugged, trouble-free performance.

**⚠ CAUTION:** Carefully read through this entire operator's manual before using your new saw.

Pay close attention to the Rules for Safe Operation, Warnings, and Cautions. If you use your saw properly and only for what it is intended, you will enjoy years of safe, reliable service.

Please fill out and return the Warranty Registration Card so we can be of future service to you.

Thank you again for buying Ryobi tools.

**SAVE THIS MANUAL FOR FUTURE REFERENCE**

# TABLE OF CONTENTS

<b>Table Of Contents</b> .....	<b>2</b>	Dust Guide .....	12
<b>Safety and International Symbols</b> .....	<b>2</b>	To Install Blade .....	12-13
<b>Rules For Safe Operation</b> .....	<b>3-6</b>	Dust Bag .....	13
Additional Rules For Safe Operation For		Table Extensions .....	14
Miter Saws .....	6	Stop Block .....	14
<b>Product Specifications</b> .....	<b>7</b>	Work Clamp (Optional) .....	15
<b>Glossary Of Terms For Woodworking</b> .....	<b>7</b>	<b>Adjustments</b> .....	<b>15-17</b>
<b>Unpacking And Checking Contents</b> .....	<b>8</b>	Pivot Adjustments .....	15
Loose Parts List .....	8	Travel Pivot Adjustment .....	15
<b>Features</b> .....	<b>9-11</b>	Squaring The Miter Table To The Fence .....	16
Know Your Miter Saw .....	9	Squaring The Saw Blade To The Fence .....	17
14 Amp Motor .....	9	<b>Operation</b> .....	<b>18-20</b>
10 in. (254 mm) Blade .....	9	Applications .....	18
Cutting Capacities .....	9	Cutting With Your Miter saw .....	18
Blade Wrench / Storage Area .....	9	Crosscutting .....	18
Carrying Handle .....	9	To Crosscut With Your Miter saw .....	18
Miter Lock Handle .....	10	Support Long Workpieces .....	19
Spindle Lock Button .....	10	Cutting Warped Material .....	20
Trigger Lock .....	10	Clamping Wide Workpieces .....	20
Positive Stops On Miter Table .....	10	<b>Maintenance</b> .....	<b>21-22</b>
Electric Brake .....	10	General .....	21
Fence .....	10	Lubrication .....	21
Self-Retracting Lower Blade Guard .....	10	Extension Cords .....	21
Mounting Holes .....	11	Brush Replacement .....	22
Optional Accessories .....	11	<b>Troubleshooting</b> .....	<b>23</b>
Electrical Connection .....	11	<b>Extension Cord Caution</b> .....	<b>24</b>
<b>Assembly</b> .....	<b>12-15</b>	<b>Parts Ordering / Service</b> .....	<b>24</b>
Miter Lock Handle .....	12		

## SAFETY AND INTERNATIONAL SYMBOLS

This operator's manual describes safety and international symbols and pictographs that may appear on this product. Read the operator's manual for complete safety, assembly, operating and maintenance and repair information.

### SYMBOL



### MEANING

- NO HANDS SYMBOL**

Failure to keep your hands away from the blade will result in serious personal injury.



- READ OPERATOR'S MANUAL**

Failure to follow operating instructions and safety precautions in operator's manual can result in serious injury. Read operator's manual before starting or operating this unit.

# RULES FOR SAFE OPERATION

The purpose of safety symbols is to attract your attention to possible dangers. The safety symbols, and the explanations with them, deserve your careful attention and understanding. The safety warnings do not by themselves eliminate any danger. The instructions or warnings they give are not substitutes for proper accident prevention measures.

SYMBOL	MEANING
	<b>SAFETY ALERT SYMBOL:</b> Indicates danger, warning, or caution. May be used in conjunction with other symbols or pictographs.
	<b>DANGER:</b> Failure to obey a safety warning will result in serious injury to yourself or to others. Always follow the safety precautions to reduce the risk of fire, electric shock and personal injury.
	<b>WARNING:</b> Failure to obey a safety warning can result in serious injury to yourself or to others. Always follow the safety precautions to reduce the risk of fire, electric shock and personal injury.
	<b>CAUTION:</b> Failure to obey a safety warning may result in property damage or personal injury to yourself or to others. Always follow the safety precautions to reduce the risk of fire, electric shock and personal injury.
<b>NOTE:</b>	Advises you of information or instructions vital to the operation or maintenance of the equipment.



## DOUBLE INSULATION

Double insulation is a concept in safety, in electric power tools, which eliminates the need for the usual three-wire grounded power cord. All exposed metal parts are isolated from internal metal motor components with protecting insulation. Double insulated tools do not need to be grounded.



### WARNING:

The double insulated system is intended to protect the user from shock resulting from a break in the tool's internal wiring. Observe all normal safety precautions related to avoiding electrical shock.

## IMPORTANT

Servicing requires extreme care and knowledge and should be performed only by a qualified service technician. When servicing, use only identical Ryobi replacement parts. For service we suggest you return the tool to your nearest **RYOBI AUTHORIZED SERVICE CENTER** for repair. Call 1-800-525-2579 in the United State or visit our web site at [www.ryobitools.com](http://www.ryobitools.com) for your nearest **RYOBI AUTHORIZED SERVICE CENTER**.



### WARNING:

Do not attempt to operate this tool until you have read thoroughly and understand completely all instructions, safety rules, etc. contained in this manual. Failure to comply can result in accidents involving fire, electric shock, or serious personal injury. Save this operator's manual and review frequently for continuing safe operation and instructing others who may use this tool.

# RULES FOR SAFE OPERATION

Safe operation of this power tool requires that you read and understand this operator's manual and all labels affixed to the tool. Safety is a combination of common sense, staying alert, and knowing how your miter saw works.

## READ ALL INSTRUCTIONS

1. **KNOW YOUR POWER TOOL.** Read the operator's manual carefully. Learn the saw's applications and limitations as well as the specific potential hazards related to this tool.
2. **GUARD AGAINST ELECTRICAL SHOCK BY PREVENTING BODY CONTACT WITH GROUNDED SURFACES.** For example: pipes, radiators, ranges, refrigerator enclosures.
3. **KEEP GUARDS IN PLACE** and in good working order.
4. **KEEP THE WORK AREA CLEAN.** Cluttered work areas and work benches invite accidents. **DO NOT** leave tools or pieces of wood on the saw while it is in operation.
5. **DO NOT USE IN DANGEROUS ENVIRONMENTS.** Do not use power tools near gasoline or other flammable liquids, in damp or wet locations, or expose them to rain. Keep the work area well lit.
6. **KEEP CHILDREN AND VISITORS AWAY.** All visitors should wear safety glasses and be kept a safe distance from work area. Do not let visitors contact tool or extension cord while operating.
7. **MAKE WORKSHOP CHILDPROOF** with padlocks and master switches, or by removing starter keys.
8. **DO NOT FORCE THE TOOL.** It will do the job better and safer at the rate for which it was designed.
9. **USE THE RIGHT TOOL.** Do not force the tool or attachment to do a job it was not designed for. Don't use it for a purpose not intended.
10. **DRESS PROPERLY.** Do not wear loose clothing, gloves, neckties, rings, bracelets, or other jewelry. They can get caught and draw you into moving parts. Nonslip footwear is recommended when working outdoors. Also wear protective hair covering to contain long hair.
11. **ALWAYS WEAR SAFETY GLASSES WITH SIDE SHIELDS.** Everyday eyeglasses have only impact-resistant lenses; they are **NOT** safety glasses.
12. **PROTECT YOUR LUNGS.** Wear a face or dust mask if the cutting operation is dusty.
13. **PROTECT YOUR HEARING.** Wear hearing protection during extended periods of operation.
14. **DO NOT ABUSE CORD.** Never yank cord to disconnect it from receptacle. Keep cord from heat, oil, and sharp edges.
15. **DO NOT OVERREACH.** Keep proper footing and balance at all times.
16. **MAINTAIN TOOLS WITH CARE.** Keep tools sharp and clean for better and safer performance. Follow instructions for lubricating and changing accessories.
17. **DISCONNECT ALL TOOLS.** When not in use, before servicing, or when changing attachments, blades, bits, cutters, etc., all tools should be disconnected.
18. **REMOVE ADJUSTING KEYS AND WRENCHES.** Get in the habit of checking to see that hex keys and adjusting wrenches are removed from tool before turning it on.
19. **AVOID ACCIDENTAL STARTING.** Be sure switch is off when plugging in.
20. **USE THE PROPER EXTENSION CORD.** Make sure your extension cord is in good condition. When using an extension cord, be sure to use one heavy enough to carry the current your product will draw. An undersized cord will cause a drop in line voltage resulting in loss of power and overheating. A wire gage size (A.W.G.) of at least **14** is recommended for an extension cord 25 feet or less in length. If in doubt, use the next heavier gage. The smaller the gage number, the heavier the cord.
21. **USE OUTDOOR EXTENSION CORDS.** When tool is used outdoors, use only extension cords with approved ground connection that are intended for use outdoors and so marked.
22. **KEEP BLADES CLEAN AND SHARP.** Sharp blades minimize stalling and kickback.
23. **KEEP HANDS AWAY FROM CUTTING AREA.** Keep hands away from blades. Do not reach underneath work or around or under the blade while blade is rotating. Do not attempt to remove cut material when blade is moving.



**WARNING:** Blades coast after turn off.

24. **NEVER USE IN AN EXPLOSIVE ATMOSPHERE.** Normal sparking of the motor could ignite fumes.
25. **INSPECT TOOL CORDS PERIODICALLY** and if damaged, have repaired at your nearest **AUTHORIZED SERVICE CENTER.** Stay constantly aware of cord location and keep it well away from the rotating blade.
26. **INSPECT EXTENSION CORDS PERIODICALLY** and replace if damaged.
27. **KEEP TOOL DRY, CLEAN, AND FREE FROM OIL AND GREASE.** Always use a clean cloth when cleaning. Never use brake fluids, gasoline, petroleum-based products, or any solvents to clean tool.
28. **STAY ALERT AND EXERCISE CONTROL.** Watch what you are doing and use common sense. **Do not operate tool when you are tired. Do not rush.**

# RULES FOR SAFE OPERATION

29. **CHECK DAMAGED PARTS.** Before further use of the tool, a guard or other part that is damaged should be carefully checked to determine that it will operate properly and perform its intended function. Check for alignment of moving parts, binding of moving parts, breakage of parts, mounting and any other conditions that may affect its operation. A guard or other part that is damaged must be properly repaired or replaced by an authorized service center to avoid risk of personal injury.
30. **DO NOT USE TOOL IF SWITCH DOES NOT TURN IT ON AND OFF.** Have defective switches replaced by an authorized service center.
31. **USE THE FENCE.** Always use the fence when cutting.
32. **SUPPORT LONG WORKPIECES.** To minimize risk of blade pinching and kickback, always support long workpieces.
33. **BEFORE MAKING A CUT, BE SURE ALL ADJUSTMENTS ARE SECURE.**
34. **USE ONLY CORRECT BLADES.** Do not use blades with incorrect size holes. Never use blade washers or blade screws that are defective or incorrect. The maximum blade capacity of your saw is 10 in. (254 mm).
35. **USE RECOMMENDED ACCESSORIES.** The use of improper accessories may cause risk of injury. Consult operator's manual for recommended accessories.
36. **NEVER STAND ON TOOL.** Serious injury could occur if the tool is tipped or if the blade is unintentionally contacted.
37. **POLARIZED PLUGS.** To reduce the risk of electric shock, this tool has a polarized plug (one blade is wider than the other). This plug will fit in a polarized outlet only one way. If the plug does not fit fully in the outlet, reverse the plug. If it still does not fit, contact a qualified electrician to install the proper outlet. Do not change the plug in any way.
38. **NEVER LEAVE TOOL RUNNING UNATTENDED. TURN THE POWER OFF.** Do not leave tool until it comes to a complete stop.
39. **TURN TOOL OFF AND WAIT FOR SAW BLADE TO STOP BEFORE RAISING SAW HEAD, MOVING WORK, OR CHANGING SETTINGS.**
40. **AVOID CUTTING NAILS.** Inspect for and remove all nails from lumber before cutting.
41. **NEVER TOUCH BLADE** or other moving parts during use.
42. **NEVER START A TOOL WHEN THE BLADE IS IN CONTACT WITH THE WORKPIECE.**
43. **DO NOT OPERATE THIS TOOL WHILE UNDER THE INFLUENCE OF DRUGS, ALCOHOL, OR ANY MEDICATION.**
44. **SECURE WORK.** Use clamps or a vise to hold work when practical. It's safer than using your hand and it frees both hands to operate tool.
45. **REPLACEMENT PARTS.** All repairs, whether electrical or mechanical, should be made at your nearest Authorized Service Center.
46. **SAVE THESE INSTRUCTIONS.** Refer to them frequently and use them to instruct other users. If you loan someone this tool, loan them these instructions also.

## **WARNING:**

When servicing use only identical Ryobi replacement parts. Use of any other parts may create a hazard or cause product damage.

## **WARNING:**



The operation of any power tool can result in foreign objects being thrown into your eyes, which can result in severe eye damage. Before beginning tool operation, always wear safety goggles or safety glasses with side shields and a full face shield when needed. We recommend Wide Vision Safety Mask for use over eyeglasses or standard safety glasses with side shields. Always wear eye protection which is marked to comply with ANSI Z87.1.



**Look for this symbol to point out important safety precautions. It means attention!!! Your safety is involved.**

# Additional Rules For Safe Operation For Miter Saws

1. **NEVER USE A DULL SAW BLADE** or one that does not have sufficient set.
2. **DO NOT REMOVE THE SAW'S BLADE GUARDS.** Never operate the saw with any guard or cover removed. Make sure all guards are operating properly before each use.
3. **MAKE SURE THE MITER TABLE IS LOCKED IN POSITION BEFORE OPERATING YOUR SAW.** Lock the miter table by securely tightening the miter lock handle.
4. **NEVER PERFORM ANY OPERATION "FREEHAND".** Always place the workpiece to be cut on the miter table and position it firmly against the fence as a backstop.
5. **ALWAYS USE A CLAMP** to secure the workpiece when possible.
6. **NEVER** hand hold a workpiece that is too small to be clamped. Keep hands clear of the no hands zone.
7. **NEVER** reach behind or under the blade and its cutting path with your hands and fingers for any reason.
8. **NEVER** stand or have any part of your body in line with the path of the saw blade.
9. **ALLOW THE MOTOR TO COME UP TO FULL SPEED** before starting a cut.
10. **ALWAYS** release the power switch and allow the saw blade to stop rotating before raising it out of the workpiece.
11. **NEVER** reach to pick up a workpiece, a piece of scrap, or anything else that is in or near the cutting path of the blade.
12. **NEVER** leave the miter saw unattended while connected to a power source.
13. **FIRMLY CLAMP OR BOLT** your miter saw to a workbench or table. The most comfortable saw table height is 39 inches or at approximately hip height.
14. **AVOID AWKWARD OPERATIONS AND HAND POSITIONS** where a sudden slip could cause your hand to move into the blade. **ALWAYS** make sure you have good balance. **NEVER** operate your miter saw on the floor or in a crouched position.
15. **ALWAYS PROVIDE ADEQUATE ROOM AND SUPPORT** for crosscutting long workpieces.
16. **NEVER USE A LENGTH STOP ON THE FREE SCRAP END OF A CLAMPED WORKPIECE.** **NEVER** hold onto or bind the free scrap end of the workpiece in any operation. If a work clamp and length stop are used together, they must both be installed on the same side of the saw table to prevent the saw from catching the loose end and kicking up.
17. **DO NOT TURN THE MOTOR SWITCH ON AND OFF RAPIDLY.** This could cause the saw blade to loosen and could create a hazard. Should this ever occur, stand clear and allow the saw blade to come to a complete stop. Disconnect your saw from the power supply and securely retighten the blade bolt.
18. **NEVER** cut more than one piece at a time. **DO NOT STACK** more than one workpiece on the saw table at a time.
19. **IF ANY PART OF THIS MITER SAW IS MISSING** or should break, bend, or fail in any way, or should any electrical component fail to perform properly, shut off the power switch, remove the miter saw plug from the power source and have damaged, missing, or failed parts replaced before resuming operation.
20. **ALWAYS STAY ALERT!** Do not allow familiarity (gained from frequent use of your saw) to cause a careless mistake. **ALWAYS REMEMBER** that a careless fraction of a second is sufficient to inflict severe injury.
21. **MAKE SURE THE WORK AREA HAS AMPLE LIGHTING** to see the work and that no obstructions will interfere with safe operation **BEFORE** performing any work using your saw.
22. **ALWAYS TURN OFF SAW** before disconnecting it, to avoid accidental starting when reconnecting to power supply.
23. **SAVE THESE INSTRUCTIONS.** Refer to them frequently and use to instruct other users. If you loan someone this tool, loan them these instructions also.



## WARNING:

Some dust created by power sanding, sawing, grinding, drilling, and other construction activities contains chemicals known to cause cancer, birth defects or other reproductive harm. Some examples of these chemicals are:

- lead from lead-based paints,
- crystalline silica from bricks and cement and other masonry products, and
- arsenic and chromium from chemically-treated lumber.

Your risk from these exposures varies, depending on how often you do this type of work. To reduce your exposure to these chemicals: work in a well ventilated area, and work with approved safety equipment, such as those dust masks that are specially designed to filter out microscopic particles.

## SAVE THESE INSTRUCTIONS

# SPECIFICATIONS

Blade Diameter .....	10 in. (254 mm)
Blade Arbor .....	5/8 in. (16 mm)
No Load Speed .....	5,000 RPM
Rating .....	120 Volts, 60 Hz-AC Only
Input .....	14 Amperes
Cutting Capacities:	
At 90°:	H x W
Max Width: 2-5/8" x 5-3/4"	
Max Height: 3-1/4" x 3-1/2"	
At 45°:	H x W
Max Width: 2-3/4" x 4"	
Max Height: 3-1/4" x 3-1/4"	
Tool Weight .....	28.2 lbs. (12.8 kg.)

## GLOSSARY OF TERMS FOR WOODWORKING

### **Arbor**

The shaft on which a blade or cutting tool is mounted.

### **Crosscut**

A cutting or shaping operation made across the grain of the workpiece.

### **Freehand**

Performing a cut without using a fence, miter gage, fixture, work clamp, or other proper device to keep the workpiece from twisting during the cut.

### **Gum**

A sticky, sap based residue from wood products.

### **Miter Cut**

A cutting operation made with the wood at any angle other than 90 degrees to the fence.

### **Resin**

A sticky, sap base substance that has hardened.

### **Revolutions Per Minute (RPM)**

The number of turns completed by a spinning object in one minute.

### **Saw Blade Path**

The area over, under, behind, or in front of the blade. As it applies to the workpiece, that area which will be, or has been, cut by the blade.

### **Set**

The distance that the tip of the saw blade tooth is bent (or set) outward from the face of the blade.

### **Throw-Back**

Throwing of a workpiece in a manner similar to a kickback. Usually associated with a cause other than the kerf closing, such as a workpiece not being against the fence, being dropped into the blade, or being placed inadvertently in contact with the blade.

### **Through Sawing**

Any cutting operation where the blade extends completely through the thickness of the workpiece.

### **Workpiece**

The item on which the cutting operation is being done. The surfaces of a workpiece are commonly referred to as faces, ends, and edges.

### **No Hands Zone**

The area between the marked lines on the left and right side of the miter table base. This zone is identified by no hands zone labels placed inside the marked lines on the miter table base. The operator's hands must stay clear of this area during any operation of the saw.

# UNPACKING AND CHECKING CONTENTS

Your Miter Saw has been shipped completely assembled except for the blade, miter lock handle, dust guide or dust bag, table extensions, and stop block.

- Remove all loose parts from the carton. Separate and check with the list of Loose Parts. *See Figure 1.*
- Remove the packing materials from around your saw.
- Carefully lift saw from the carton and place it on a level work surface. Although small, this saw is heavy. To avoid back injury, get help when needed.
- Do not discard the packing materials until you have carefully inspected the saw, identified all loose parts, and satisfactorily operated your new saw.
- Your saw has been shipped with the saw arm locked in the down position. To release saw arm, push down on top of saw arm and pull out the lock pin. *See Figure 3.*
- Lift the saw arm by the handle. Hand pressure should remain on the saw arm to prevent sudden rise upon release of the lock pin.
- Examine all parts to make sure no breakage or damage has occurred during shipping.

If any parts are damaged or missing, do not attempt to plug in the power cord and turn the switch on until the damaged or missing parts are obtained and are installed correctly. Contact your nearest Ryobi dealer or call 1-800-525-2579 in the United States for assistance if any parts are missing or damaged.

## WARNING:

If any parts are missing do not operate your saw until the missing parts are replaced. Failure to do so could result in possible serious injury.

## LOOSE PARTS LIST

The following items are included with your Miter Saw:

- 10 in. (254 mm) Blade
- Miter Lock Handle
- Dust Bag
- Dust Guide
- Stop Block
- Small Wing Screw (for use with stop block)
- Table Extensions (2)
- Clamp Bracket (2), (for use with table extensions)
- Clamp Bracket Screw (2), (for use with table extensions)
- Blade Wrench (1/4 in. Hey Key/Phillips Screwdriver)
- Operator's Manual
- Warranty Registration

Some models may include one or more of the following accessories:

- Work Clamp
- 8 mm Work Clamp Screw

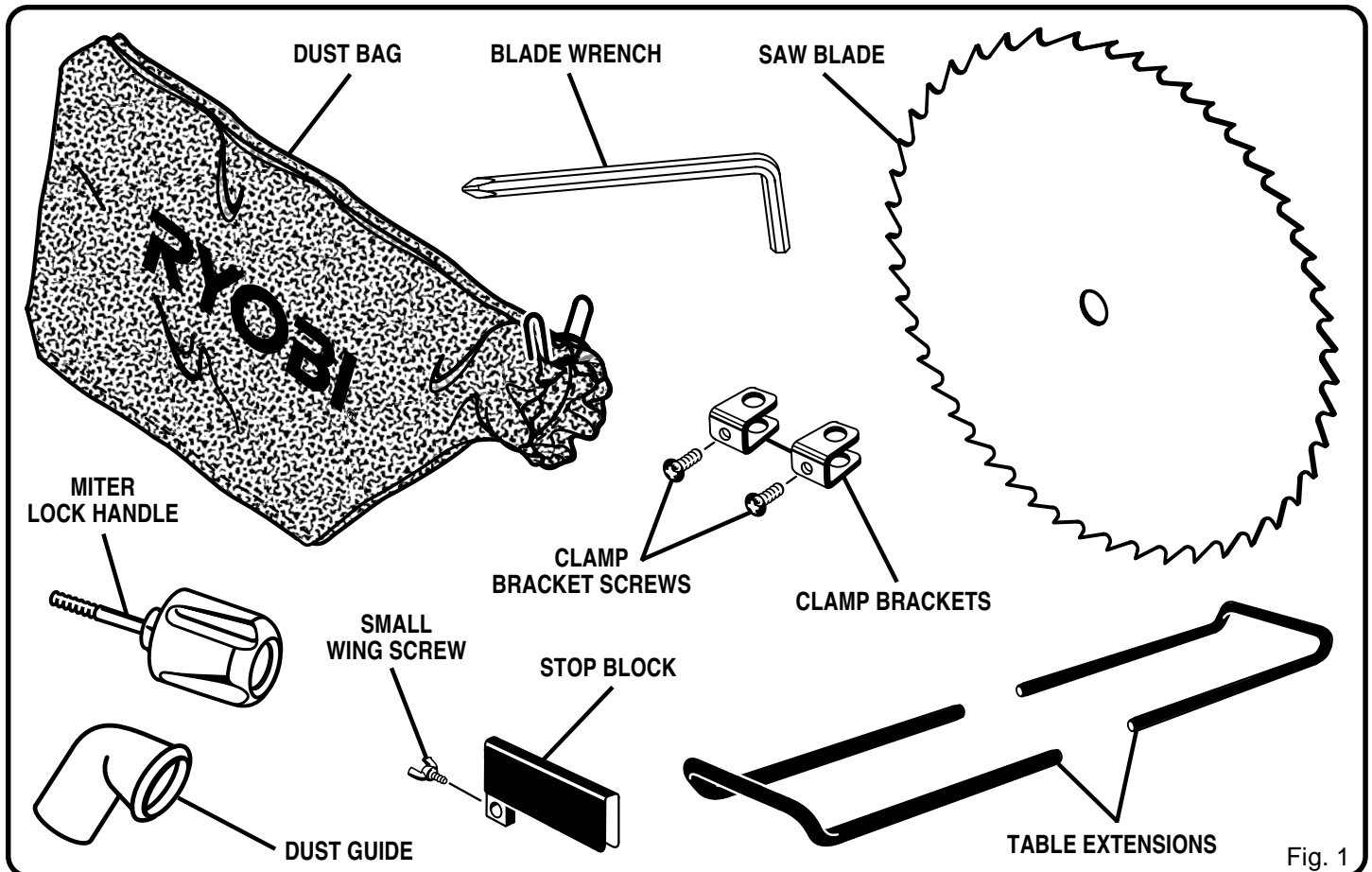

Fig. 1



# FEATURES

## KNOW YOUR MITER SAW

See Figure 2.

Before attempting to use your saw, familiarize yourself with all operating features and safety requirements.

### WARNING:

Do not allow familiarity with your miter saw to make you careless. Remember that a careless fraction of a second is sufficient to inflict severe injury.

## 14 AMP MOTOR

Your saw has a powerful 14 amp motor with sufficient power to handle tough cutting jobs. It is made with all ball bearings, and has externally accessible brushes for ease of servicing.

## 10 in. (254 mm) BLADE

A 10 in. (254 mm) saw blade is included with your miter saw. It is fine for most wood cutting operations, but for fine joinery cuts or cutting plastic, use one of the accessory blades available from your nearest Ryobi dealer.

## CUTTING CAPACITIES

**When the miter angle (miter table) is set at 0°:**

Your saw will cut dimensional lumber up to a 2 x 6.

**When the miter angle (miter table) is set at 45°:**

Your saw will cut dimensional lumber up to a 2 x 4.

## BLADE WRENCH / STORAGE AREA

See Figure 2.

A blade wrench is packed with your saw. One end of the wrench is a phillips screwdriver and the other end is a 1/4 in. (6.4 mm) hex key. Use the hex key end when installing or removing blade and the phillips end when removing or loosening screws. A storage area for the blade wrench is located behind the fence.

## CARRYING HANDLE

See Figure 3.

For convenience when carrying or transporting your miter saw from one place to another, a carrying handle has been provided on top of the saw arm as shown in figure 3. To transport, turn off and unplug your saw, then lower the saw arm and lock it in the down position. Lock saw arm by depressing the lock pin. Tighten the miter lock handle. Remove the saw from the workbench or workstand. It is now ready to transport.

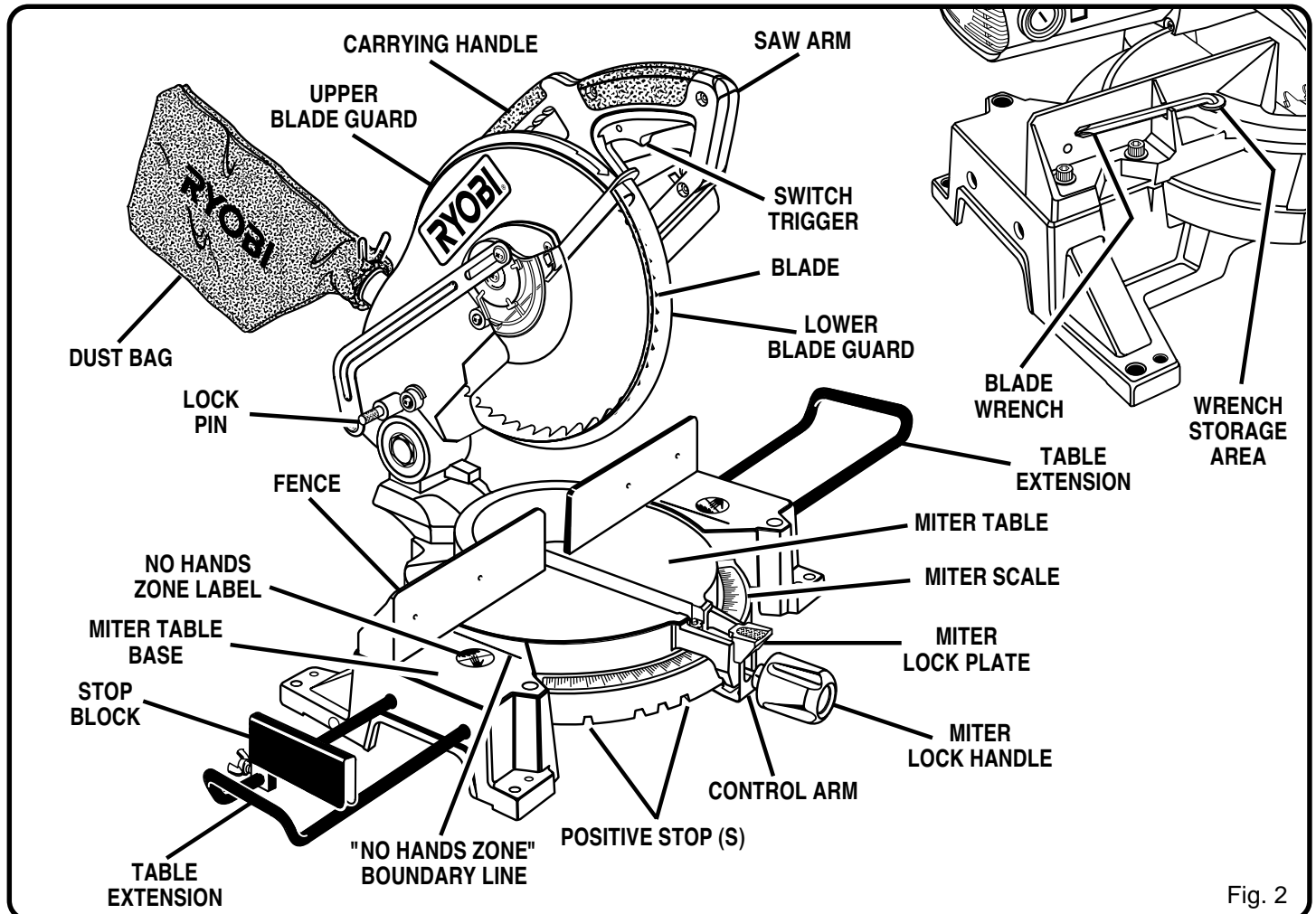

Fig. 2

# FEATURES

## MITER LOCK HANDLE

See Figure 3.

The miter lock handle securely locks your saw at desired miter angles.

## SPINDLE LOCK BUTTON

See Figure 4.

A spindle lock button has been provided for locking the spindle of your saw in a stationary position. Depress and hold the spindle lock button while installing, changing, or removing blade.

## TRIGGER LOCK

See Figure 5.

To prevent unauthorized use of your miter saw, we suggest that you disconnect it from the power supply and lock the switch in the off position. To lock the switch, install a padlock through the hole in the switch trigger. A lock with a shackle between 1/4 in. (6.4 mm) and 19/64 in. (7.5 mm) diameter may be used. When the lock is installed and locked, the switch is inoperable. Store the padlock key in another location.

## POSITIVE STOPS ON MITER TABLE

Positive stops have been provided at 0°, 15°, 22-1/2°, 30°, and 45°. The 15°, 22-1/2°, 30°, and 45° positive stops have been provided on both the left and right side of the miter table.

## ELECTRIC BRAKE

An electric brake has been provided to quickly stop blade rotation after the switch is released.

## FENCE

The fence on your miter saw has been provided as a support to hold your workpiece securely against when making all cuts.

## SELF-RETRACTING LOWER BLADE GUARD

The lower blade guard is made of shock-resistant, see-through plastic that provides protection from each side of the blade. It retracts over the upper blade guard as the saw is lowered into the workpiece.

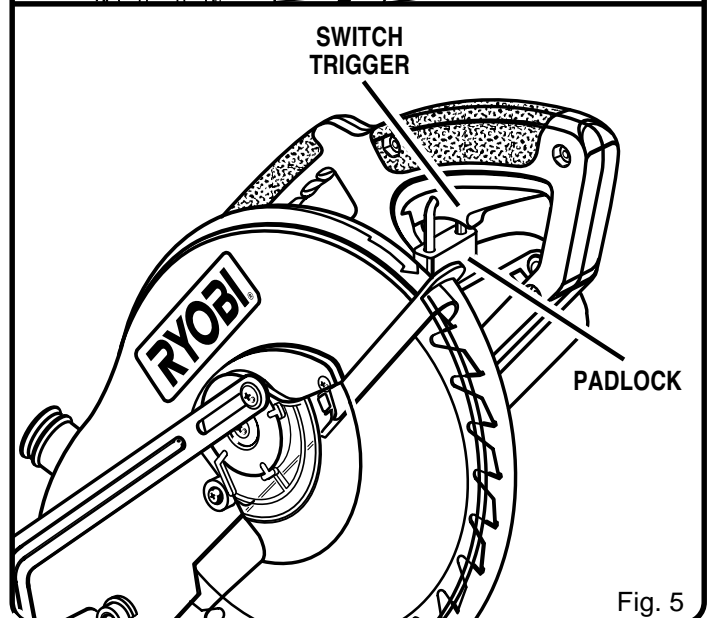
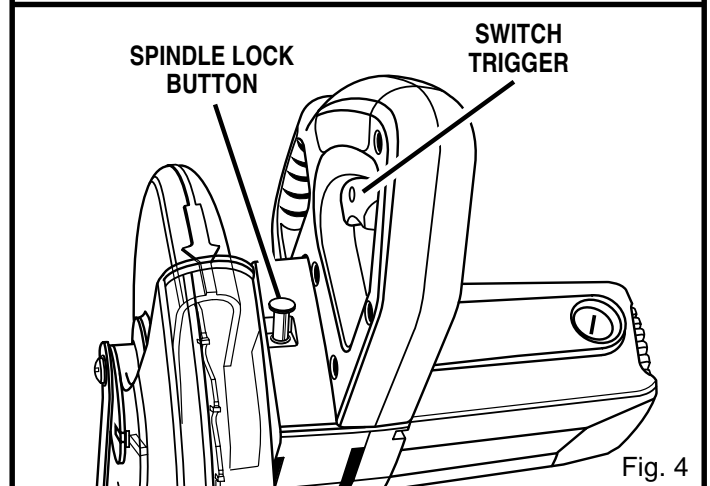
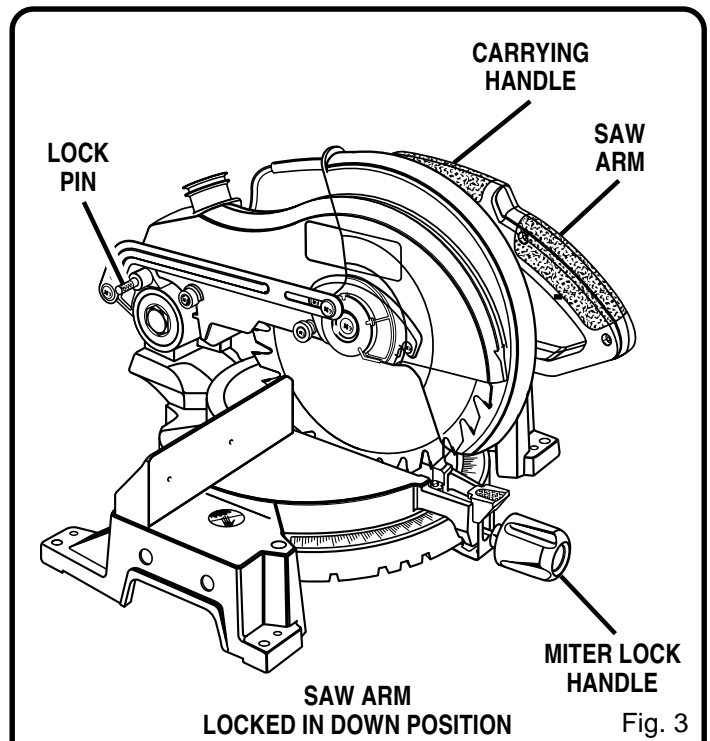

# FEATURES

## MOUNTING HOLE

See Figure 6.

Your miter saw should be mounted to a firm supporting surface such as workbench. Four bolt holes have been provided in the saw base for this purpose. Each of the four mounting holes should be bolted securely using 3/8 in. (10 mm) machine bolts, lock washers, and hex nuts (not included). Bolts should be of sufficient length to accommodate the saw base, lock washers, hex nuts, and the thickness of the workbench.

Tighten all four bolts securely.

The hole pattern, shown in figure 6, is for an 18 in. (457 mm) x 24 in. (610 mm) workbench. Carefully check the workbench after mounting to make sure that no movement can occur during use. If any tipping, sliding, or walking is noted, secure the workbench to the floor before operating.

## OPTIONAL ACCESSORIES

Optional accessories, provided on some models, are available for use with your saw. They include table extensions, a stop block, work clamp, and dust bag.

Table extensions increase the work surface to 36 in. (914 mm) wide, providing support for cutting long workpieces.

The stop block provides a stop for making repetitive cuts to same length. It can be installed on either side of saw base.

The work clamp provides a means for clamping workpiece securely against the fence when making a cut. Standard "C" clamps can also be used for this purpose.

The dust bag catches sawdust, helping keep work area cleaner.

If these accessories were not provided with our saw, they are available from your Ryobi dealer. For the location of a distributor near you, call 1-800-525-2579 in the United States.

## ELECTRICAL CONNECTION

Your saw has a precision built electric motor. It should be connected to a **power supply that is 120 volts, 60 Hz, AC only (normal household current)**. Do not operate this tool on direct current (DC). A substantial voltage drop will cause a loss of power and the motor will overheat. If your tool does not operate when plugged into an outlet, double-check the power supply.

### ⚠ WARNING:

The operation of any saw can result in foreign objects being thrown into your eyes, which can result in severe eye damage. Before starting power tool operation, always wear safety goggles or safety glasses with side shields and a full face shield when needed. We recommend wide vision safety mask for use over eyeglasses or standard safety glasses with side shields.

### ⚠ WARNING:

Do not attempt to modify this tool or create accessories not recommended for use with this tool. Any such alteration or modification is misuse and could result in a hazardous condition leading to possible serious personal injury.

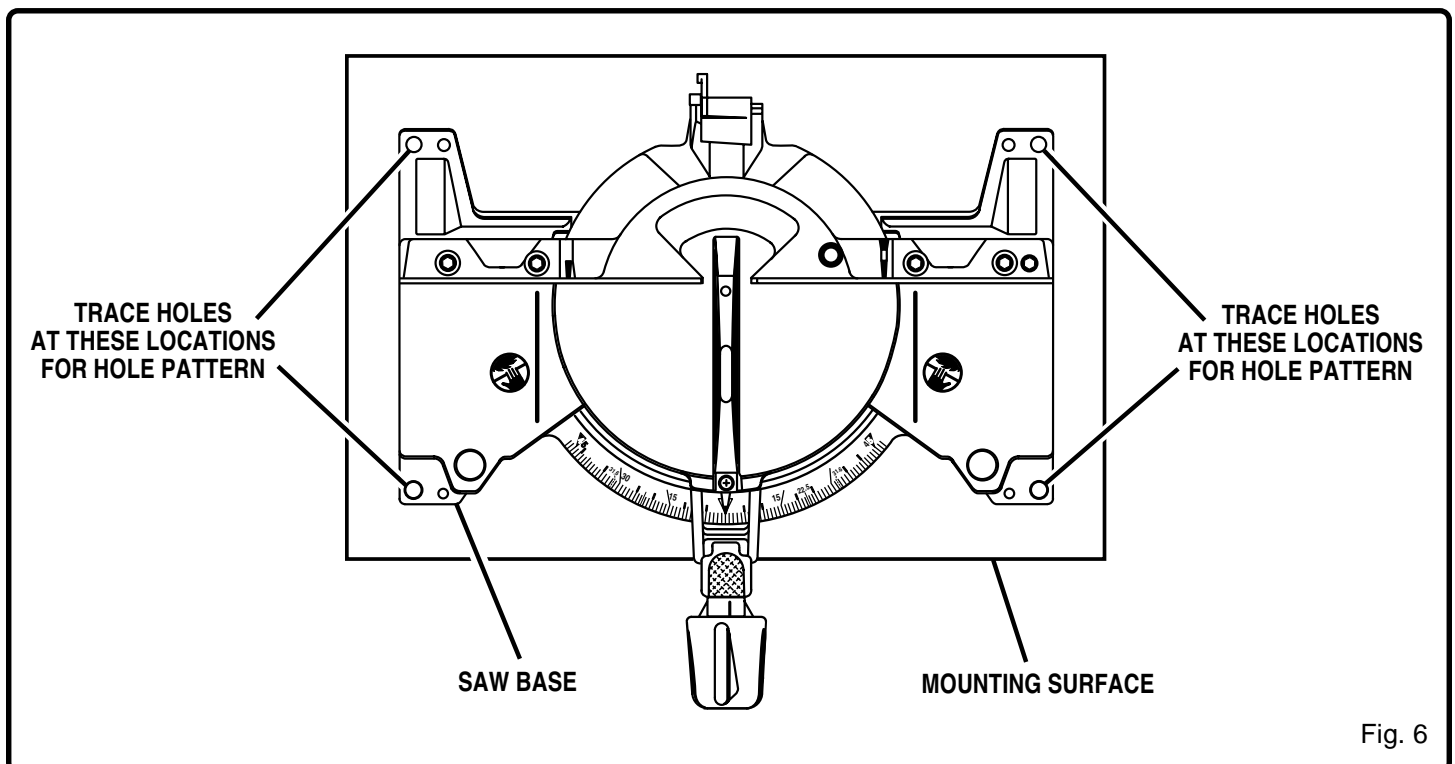

Fig. 6

# ASSEMBLY

## **WARNING:**

To prevent accidental starting that could cause possible serious personal injury, assemble all parts, make sure all adjustments are complete, and make sure all fasteners are secure before connecting saw to power supply. Saw should never be connected to power supply when you are assembling parts, making adjustments, installing or removing blades, or when not in use.

As mentioned previously your saw has been factory assembled and adjusted. The miter lock handle, dust guide or dust bag, table extensions, stop block, and blade are the only parts that have to be installed.

### **MITER LOCK HANDLE**

See Figure 7.

To install the miter lock handle, place the threaded stud on the end of the miter lock handle into the threaded hole in the control arm under miter table. Turn clockwise to tighten.

### **DUST GUIDE**

See Figure 8.

To install the dust guide, place the end marked **INSERT** over the exhaust port in the upper blade guard. Turn the guide so that the open end is facing down.

### **TO INSTALL BLADE**

See Figures 9, 10, and 11.

## **WARNING:**

A 10 in. (254 mm) blade is the maximum blade capacity of your saw. Never use a blade that is too thick to allow outer blade washer to engage with the flats on the spindle. Larger blades will come in contact with the blade guards, while thicker blades will prevent the blade bolt from securing the blade on the spindle. Either of these situations could result in a serious accident and can cause serious personal injury.

- Unplug your saw.

## **WARNING:**

Failure to unplug your saw could result in accidental starting causing possible serious personal injury.

- Insert the wrench provided through slot in lower blade guard bracket and loosen screw A, securing the blade bolt cover, approximately one-half turn. See Figure 9.
- Rotate lower blade guard up and remove screw B. Rotate blade bolt cover up and back to expose the blade bolt.
- Push down on the saw arm and pull out the lock pin to release saw arm. Raise saw arm to its full raised position. Be cautious, saw arm is spring loaded to raise.

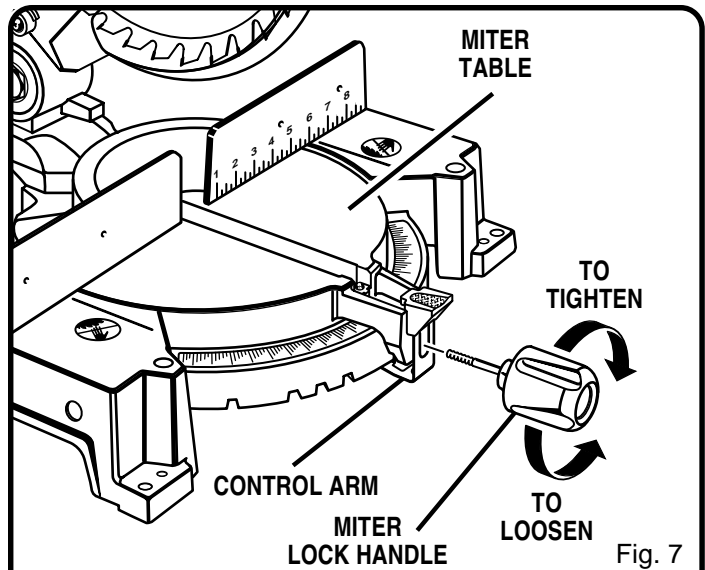

Fig. 7

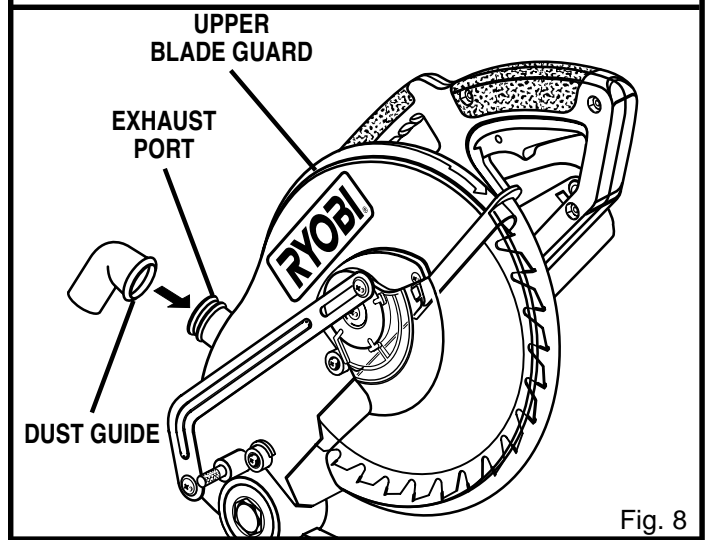

Fig. 8

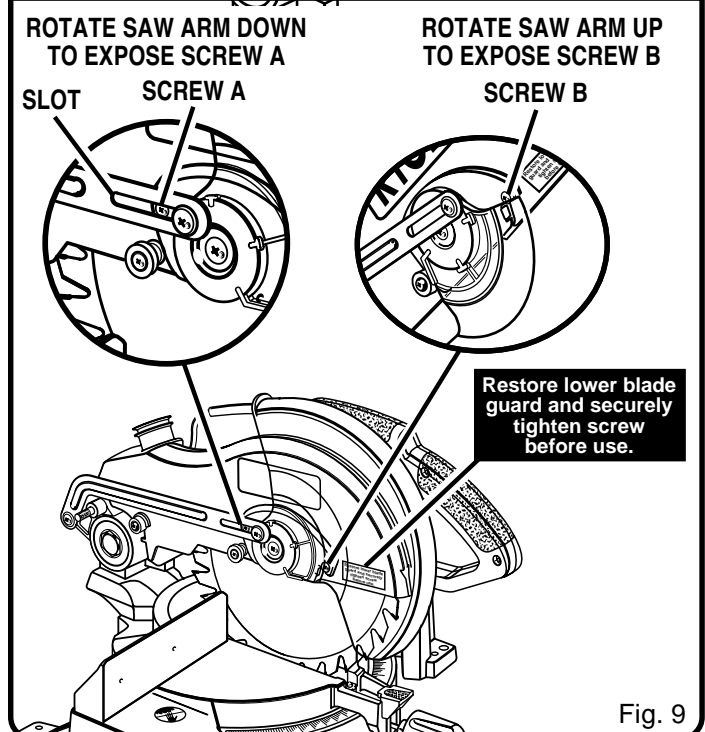

Fig. 9

# ASSEMBLY

- Depress the spindle lock button and rotate the blade bolt until the spindle locks. *See Figure 10.*
- Using the wrench provided, loosen and remove the blade bolt.
  - NOTE:** The blade bolt has left hand threads. Turn blade bolt clockwise to loosen.
- Remove outer blade washer. **Do not** remove inner blade washer.
- Wipe a drop of oil onto inner blade washer and outer blade washer where they contact the blade.

## **WARNING:**

If inner blade washer has been removed, replace it before placing blade on spindle. Failure to do so could cause an accident since blade will not tighten properly.

- Fit saw blade inside lower blade guard and onto spindle. The blade teeth point downward at the front of saw as shown in figure 11.

## **CAUTION:**

Always install the blade with the blade teeth and the arrow printed on the side of the blade pointing down at the front of the saw. The direction of blade rotation is also stamped with an arrow on the upper blade guard.

- Replace outer blade washer. The double "D" flats on the blade washers align with the flats on the spindle.
- Depress spindle lock button and replace blade bolt.
  - NOTE:** The blade bolt has left hand threads. Turn blade bolt counterclockwise to tighten.
- Tighten blade bolt securely.
- Replace the lower blade guard and blade bolt cover.
- Replace screw B and tighten securely.
- Retighten screw A securely.
- Replace wrench in storage area.

## **WARNING:**

Make sure the spindle lock button is not engaged before reconnecting saw into power source. Never engage spindle lock button when blade is rotating.

## DUST BAG

*See Figure 12.*

A dust bag is provided for use on your miter saw. It fits over the exhaust port on the upper blade guard. To install it, remove dust guide from exhaust port. Then, squeeze the two metal clips to open the mouth of the bag and slide it on the exhaust port. Release the clips. The metal ring in the bag should lock in between the grooves on the exhaust port.

To remove the dust bag for emptying, simply reverse the above procedure.

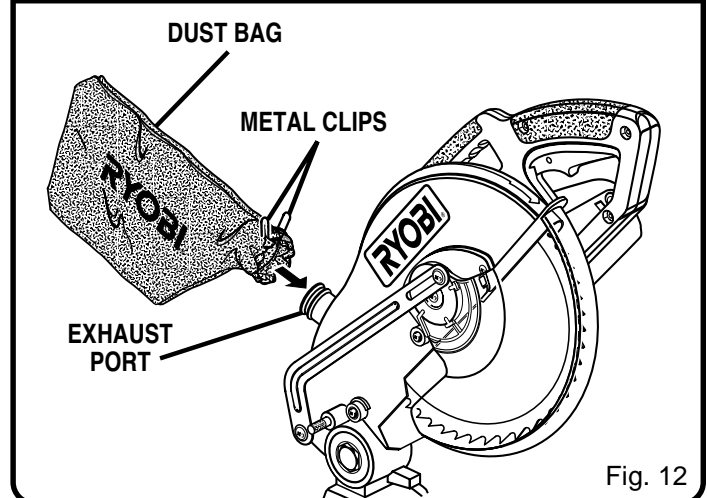
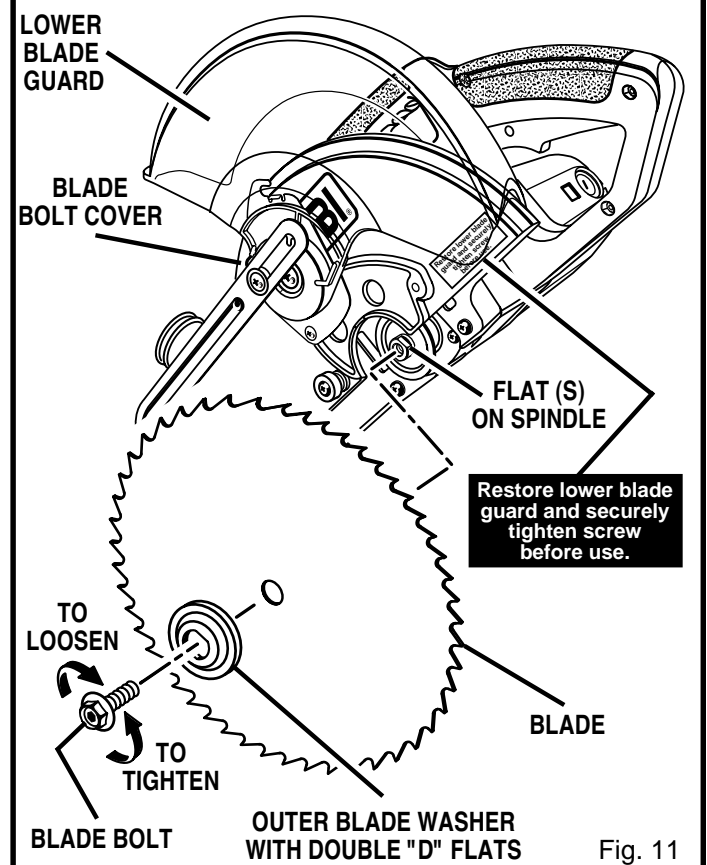
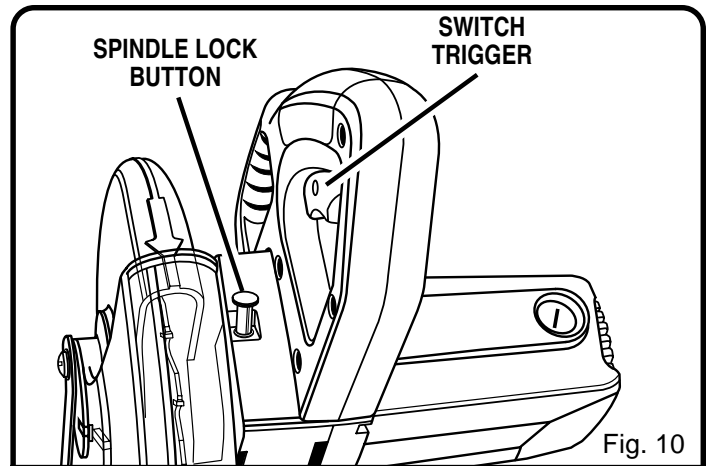

# ASSEMBLY

## TABLE EXTENSIONS

See Figures 13, 14, and 15.

If you plan to use the stop block, slide the stop block on the back arm of the desired table extension first. See Figure 13.

To install table extensions, insert the ends of extensions into the holes in the sides of the base. See Figures 13 and 14. Adjust the extensions to the desired length.

Secure them in place by positioning a clamp bracket under each table extension beneath the miter table. Orient each clamp bracket as shown in figure 15.

Secure each clamp bracket in place with a clamp bracket screw. The clamp bracket screw threads through the clamp bracket and tightens against bracket support on bottom of miter table, securing clamp bracket against table extension.

## STOP BLOCK

See Figures 13 and 16.

The stop block is included with the Table extensions and is useful as a stop for making repetitive cuts to the same length. It can be installed on either side of the saw base:

- Slide the stop block on the back arm of either table extension, then insert the table extensions into the saw base. See Figure 13.
- Use the small wing screw to secure the stop block to the table extensions. See Figure 13.
- Loosen the small wing screw and adjust the stop block the desired distance from the blade for the cut to be made. For accurate placement of the stop block, measure the distance from the teeth set on the blade to the stop block.
- Tighten wing screw securely.
- Make a test cut in scrap material and measure the length of the workpiece.
- Make any necessary adjustments.

### WARNING:

Always make sure your miter saw is securely mounted to a workbench or an appropriate workstand. Failure to do so could result in an accident resulting in possible serious personal injury.

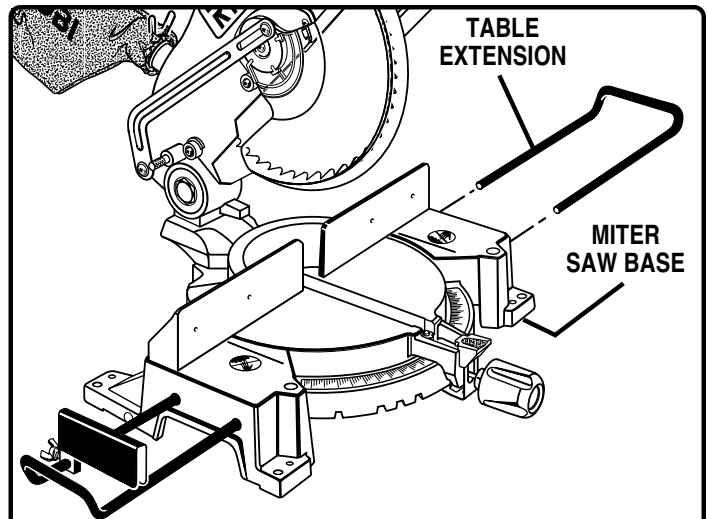
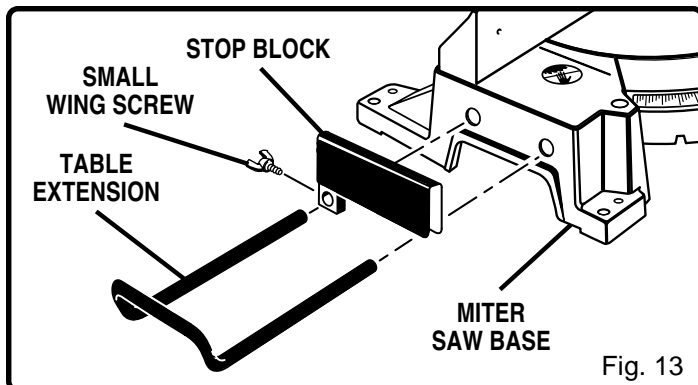

Fig. 14

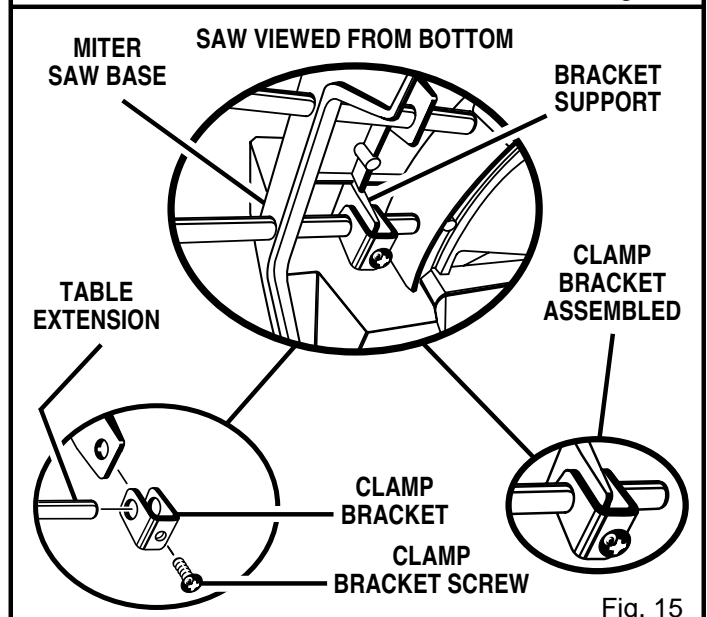

Fig. 15

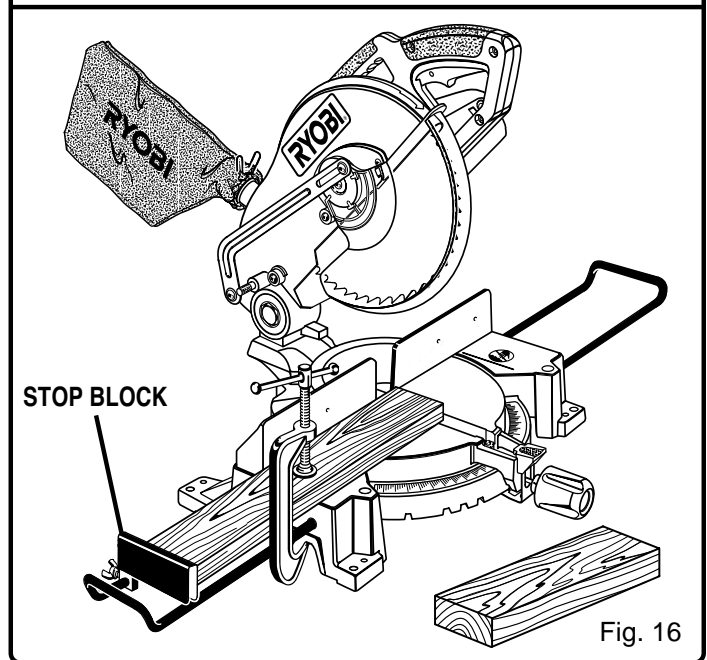

Fig. 16

# ASSEMBLY

## **WARNING:**

Before connecting saw to power source, make sure the saw blade or blade guard will not hit the table extensions or work clamp when cutting 35° to 45° angles.

## **WARNING:**

When using any clamp with the stop block, install the clamp on the same side as the stop block. This will eliminate the possibility of trapping the workpiece, resulting in the saw blade and workpiece kicking up. Failure to heed this warning can result in serious personal injury.

### **WORK CLAMP (Optional)**

Whether using a C-Clamp or the optional work clamp, part number 982021-001, available for your saw, they provide a means of clamping the work to the fence or table. Clamping secures the work and prevents the workpiece from creeping toward the saw blade. This is very helpful when cutting miters.

# ADJUSTMENTS

Your Ryobi miter saw has been adjusted at the factory for making very accurate cuts. However, some of the components might have been jarred out of alignment during shipping. Also, over a period of time, readjustment will probably become necessary due to wear. After unpacking your saw, check the following adjustments before you begin using saw. Make any readjustments that are necessary and periodically check the parts alignment to make sure that your saw is cutting accurately.

## **WARNING:**

Your saw should never be connected to power supply when you are assembling parts, making adjustments, installing or removing blades, or when not in use. Disconnecting your saw will prevent accidental starting that could cause serious injury.

**NOTE:** Many of the illustrations in this manual show only portions of your miter saw. This is intentional so that we can clearly show points being made in the illustrations. Never operate your saw without all guards securely in place and in good operating condition.

### **PIVOT ADJUSTMENTS**

**NOTE:** These adjustments were made at the factory and normally do not require readjustment.

#### **TRAVEL PIVOT ADJUSTMENT**

- The saw arm should rise completely to the up position by itself.
- If the saw arm does not raise by itself or if there is play in the pivot joints, have saw repaired at your nearest **RYOBI AUTHORIZED SERVICE CENTER**.

# ADJUSTMENTS

## SQUARING THE MITER TABLE TO THE FENCE

See Figures 17 - 20.

- Unplug your saw.

### **WARNING:**

Failure to unplug your saw could result in accidental starting causing possible serious personal injury.

- Push down on the saw arm and pull out the lock pin to release the saw arm. See Figure 3.
- Raise saw arm to its full raised position.
- Loosen the miter lock handle approximately one-half turn.
- Depress the miter lock plate and rotate the miter table until the pointer on the control arm is positioned in the positive stop at 0°.
- Release the miter lock plate and securely tighten the miter lock handle.
- Lay a framing square flat on the miter table. Place one leg of the square against the fence. Place the other leg of the square beside the blade slot in the miter table. The edge of the square and the blade slot in the miter table should be parallel as shown in figure 17.
- If the edge of the framing square and the blade slot in the miter table are not parallel as shown in figures 18 and 19, adjustments are needed.
- Using the wrench provided, loosen the socket head screws securing the fence. See Figure 20. Adjust the fence left or right until the framing square and blade slot are parallel.
- Retighten the screws securely and recheck the fence-to-table alignment.

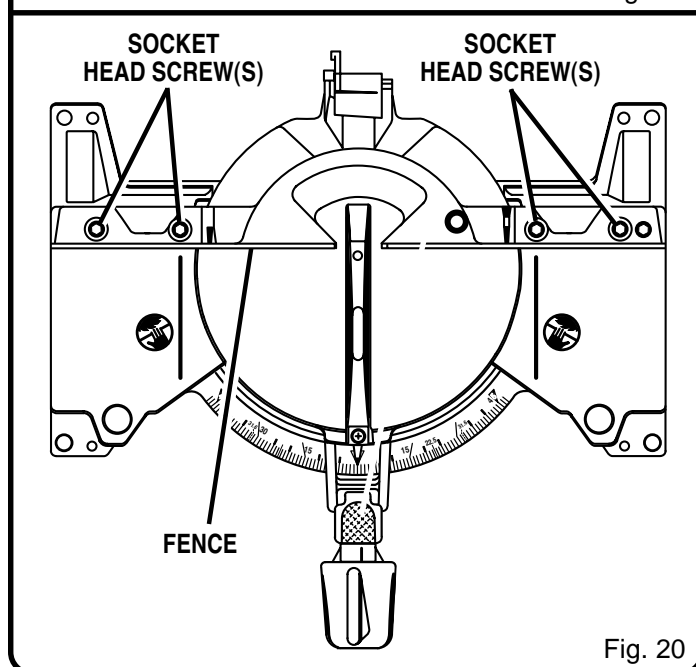
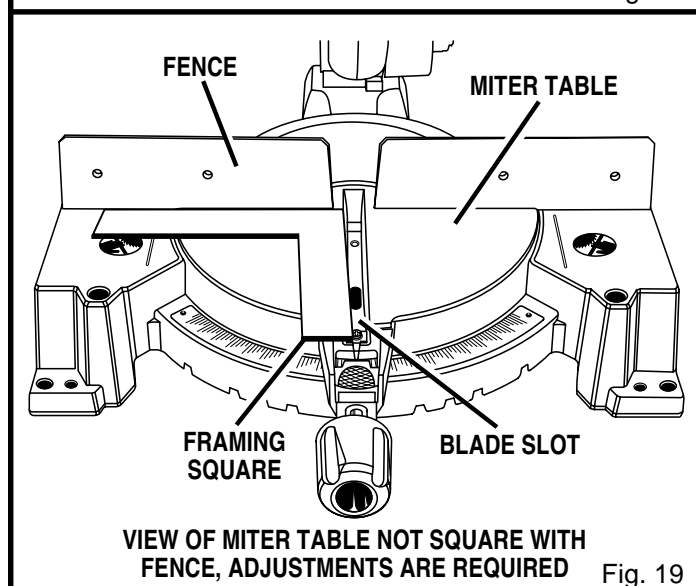
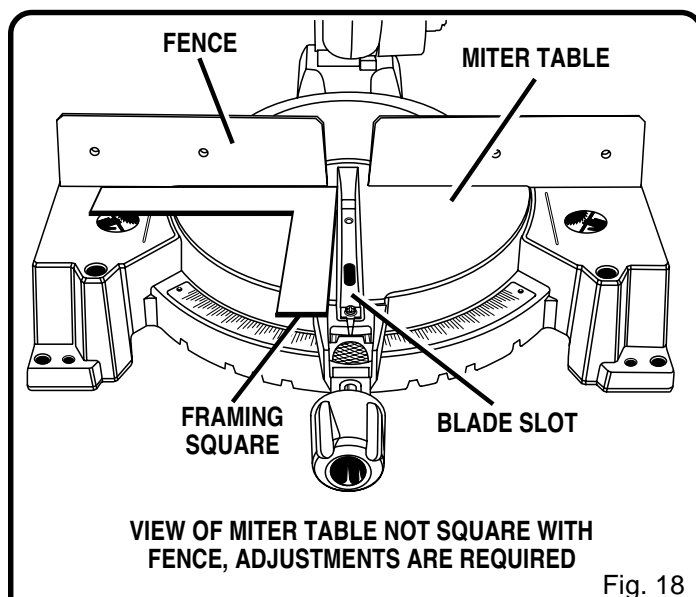
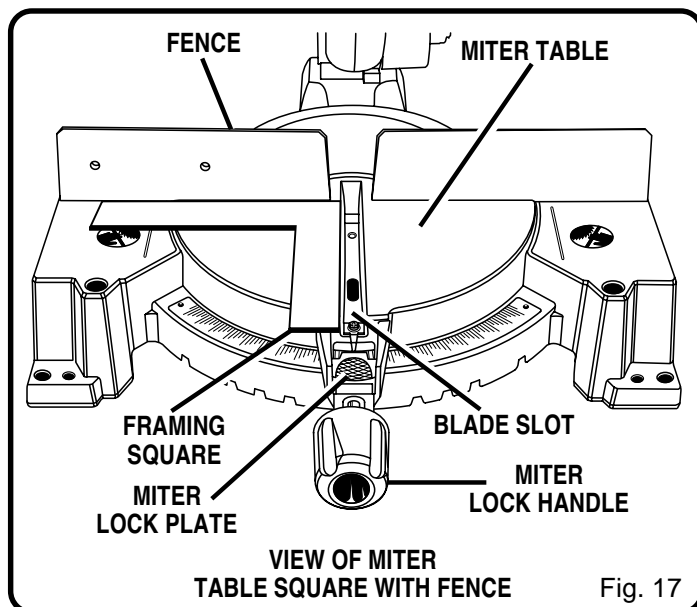



# ADJUSTMENTS

## SQUARING THE SAW BLADE TO THE FENCE

See Figures 21 - 24.

- Unplug your saw.

### **WARNING:**

Failure to unplug your saw could result in accidental starting causing possible serious personal injury.

- If saw is mounted to a workbench, it must be unmounted to square the saw blade to the fence.
- Pull the saw arm all the way down and engage the lock pin to hold the saw arm in transport position. See Figure 3.
- Place saw on a large, stable work surface.
- Loosen the miter lock handle approximately one-half turn.
- Position saw in tilted position as shown in figure 24, to locate the two socket head screws under the miter table.

### **CAUTION:**

To prevent loss of control of your saw, hold saw base with one hand while loosening the socket head screws with your other hand.

- Using a 10 mm hex key, loosen the two socket head screws.
- Reposition saw to its normal operating position.
- Lay a framing square flat on the miter table. Place one leg of the square against the fence. Slide the other leg of the square against the flat part of saw blade.

**NOTE:** Make sure that the square contacts the flat part of the saw blade, not the blade teeth.

- The edge of the square and the saw blade should be parallel as shown in figure 21.
- If the front or back edge of the saw blade angles away from the square as shown in figures 22 and 23, adjustments are needed.
- Using the miter lock handle, move the miter table left or right until the saw blade is parallel to the square.
- Position saw in tilted position as shown in figure 24 and tighten the two socket head screws securely.
- Reposition saw to its normal operating position.
- Recheck the fence-to-table alignment.

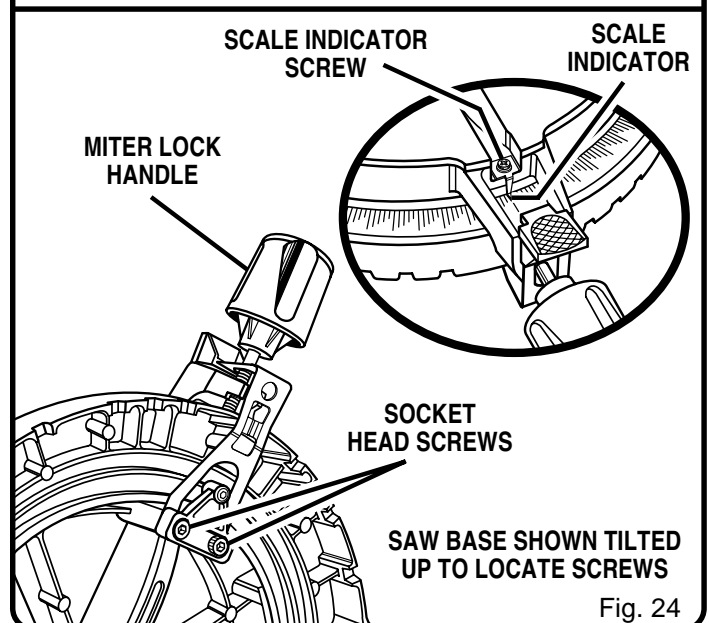
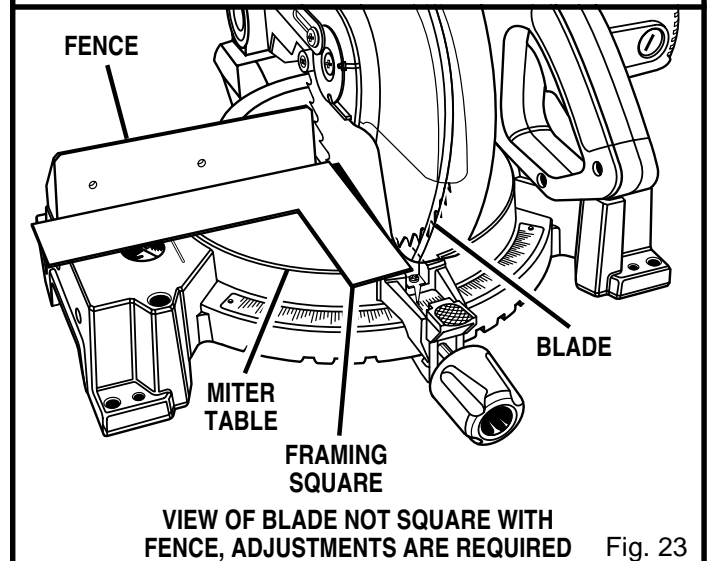
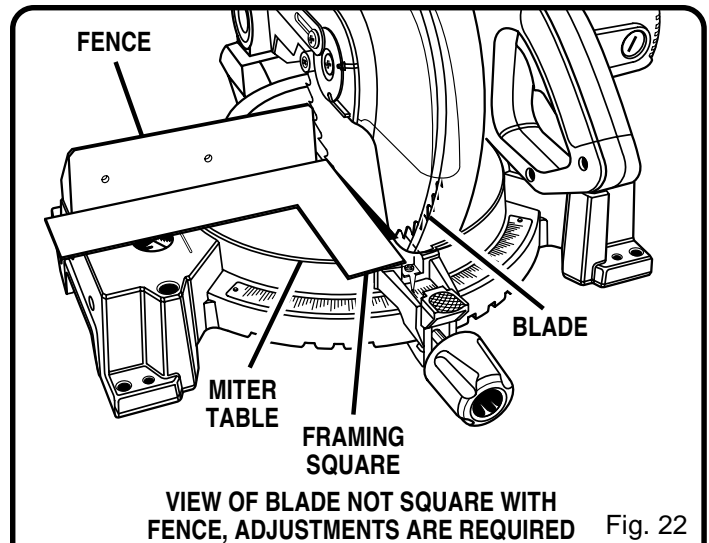
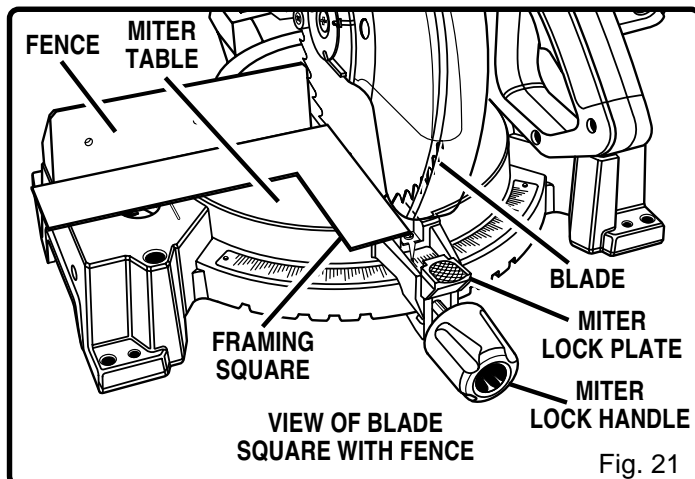

**NOTE:** After squaring adjustments have been made, it may be necessary to loosen the scale indicator screw and reset the indicator to zero.

# OPERATION

## APPLICATIONS

(Use only for the purposes listed below)

- Cross cutting wood and plastic.
- Cross cutting miters, joints, etc. for picture frames, moldings, door casings, and fine joinery.

**NOTE:** The crosscut blade provided is fine for most wood cutting operations, but for fine joinery cuts or cutting plastic, use one of the accessory blades available from your Ryobi dealer.

### **WARNING:**

Before starting any cutting operation, clamp or bolt your miter saw to a workbench. Never operate your miter saw on the floor or in a crouched position. Failure to heed this warning can result in serious personal injury.

## CUTTING WITH YOUR MITER SAW

### **WARNING:**

When using a work clamp or C-clamp to secure your workpiece against the fence, clamp workpiece on one side of the blade only. The workpiece must remain free on one side of the blade to prevent the blade from binding in workpiece. The workpiece binding the blade will cause motor stalling and kickback. This situation could cause an accident resulting in possible serious personal injury.

## CROSSCUTTING

See Figure 25.

A crosscut is made by cutting across the grain of the workpiece. A straight crosscut is made with the miter table set at the zero degree position. Miter crosscuts are made with the miter table set at some angle other than zero.

### TO CROSSCUT WITH YOUR MITER SAW:

- Pull out the lock pin and lift saw arm to its full height.
- Loosen the miter lock handle. Rotate the miter lock handle approximately one-half turn to the left to loosen.
- Press the miter lock plate down with your thumb and hold.
- Rotate the control arm until the pointer aligns with the desired angle on the miter scale.
- Release the miter lock plate.

**NOTE:** You can quickly locate 0°, or 15°, 22-1/2°, 30°, and 45° left or right by releasing the miter lock plate as you rotate the control arm. The miter lock plate will seat itself in one of the positive stop notches, located in the miter table frame.

- Tighten the miter lock handle securely.

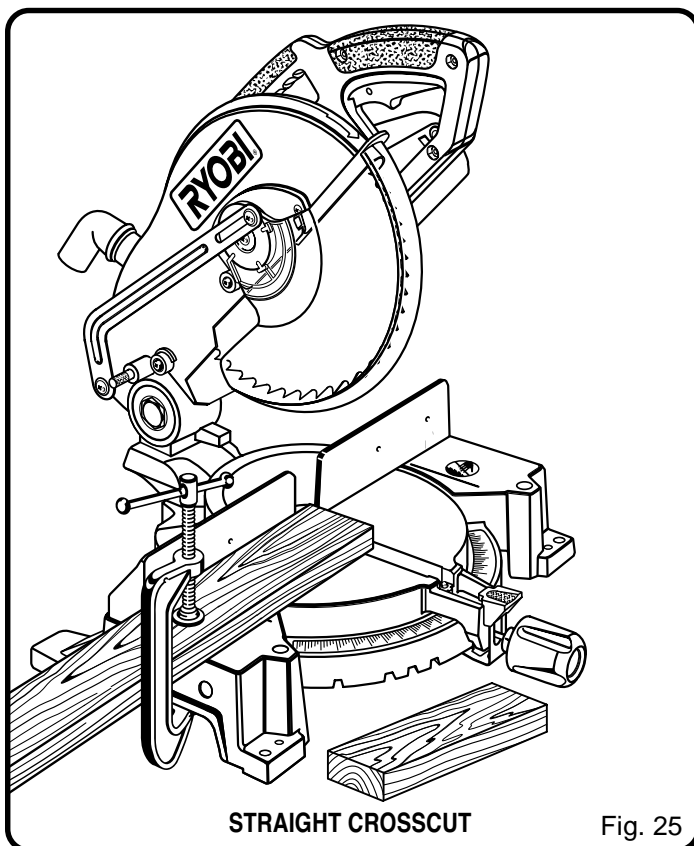

### **WARNING:**

To avoid serious personal injury, always tighten the miter lock handle securely before making a cut. Failure to do so could result in movement of the control arm or miter table while making a cut.

- Place the workpiece flat on the miter table with one edge securely against the fence. If the board is warped, place the convex side against the fence. If the concave edge of a board is placed against the fence, the board could collapse on the blade at the end of the cut, jamming the blade. See Figures 27 and 28.
- When cutting long pieces of lumber or molding, support the opposite end of the stock with a roller stand or with a work surface level with the saw table. See Figure 25.
- Align cutting line on the workpiece with the edge of saw blade.
- Grasp the stock firmly with one hand and secure it against the fence. Use the work clamp or a C-clamp to secure the workpiece when possible.

### **WARNING:**

To avoid serious personal injury, keep your hands outside the no hands zone and at least 3 in. (76.2 mm) from blade. Never perform any cutting operation freehand (without securing workpiece against the fence). The blade could grab the workpiece if it slips or twists.

# OPERATION

- Before turning on the saw, perform a dry run of the cutting operation just to make sure that no problems will occur when the cut is made.
- Grasp the saw handle firmly then squeeze the switch trigger. Allow several seconds for the blade to reach maximum speed.
- Slowly lower the blade into and through the workpiece.
- Release the switch trigger and allow the saw blade to stop rotating before raising the blade out of workpiece. Wait until the electric brake stops blade from turning before removing the workpiece from the miter table.

## SUPPORT LONG WORKPIECES

See Figure 26.

Long workpieces need extra supports. Supports should be placed along the workpiece so it does not sag. The support should let the workpiece lay flat on the base of the saw and work table during the cutting operation. Use the work clamp or a C-clamp to secure the workpiece.

### **WARNING:**

To avoid serious personal injury, always keep your hands outside the no hands zone and at least 3 in. (76.2 mm) from blade. Never perform any cutting operation freehand (without securing workpiece against the fence). The blade could grab the workpiece if it slips or twists.

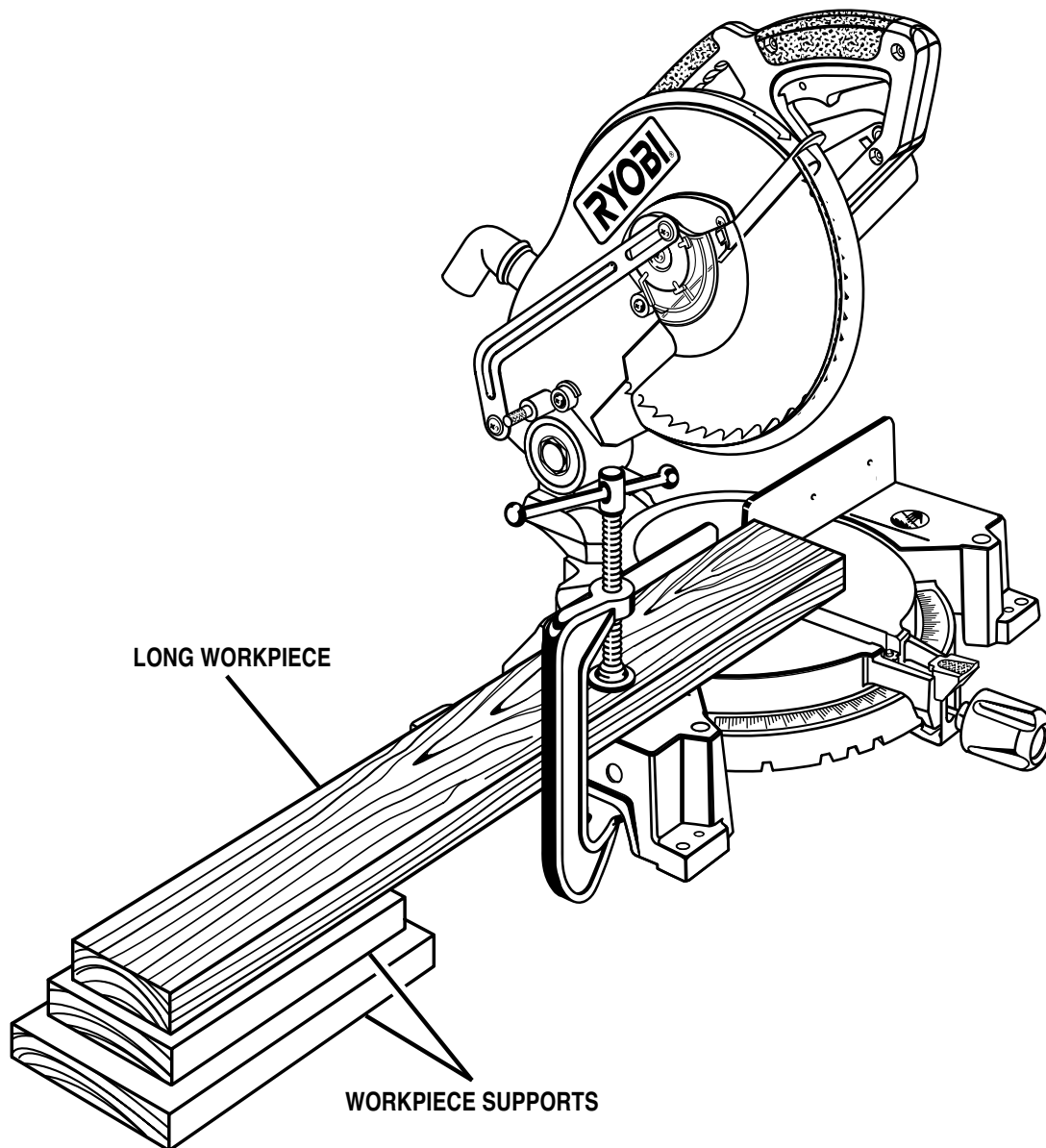

Fig. 26

# OPERATION

## CUTTING WARPED MATERIAL

See Figures 27 and 28.

When cutting warped material, always make sure it is positioned on the miter table with the convex side against the fence as shown in figure 27.

If the warped material is positioned the wrong way as shown in figure 28, it will pinch the blade near the completion of the cut.



### WARNING:

To avoid a kickback and to avoid serious personal injury, never position the concave edge of bowed or warped material against the fence.

## CLAMPING WIDE WORKPIECES

See Figure 29.

When cutting wide workpieces that are too wide to be clamped with a work clamp, a C-clamp must be used. For example, when cutting 2 in. x 6 in. boards, they should be clamped with a C-clamp as shown in figure 29.

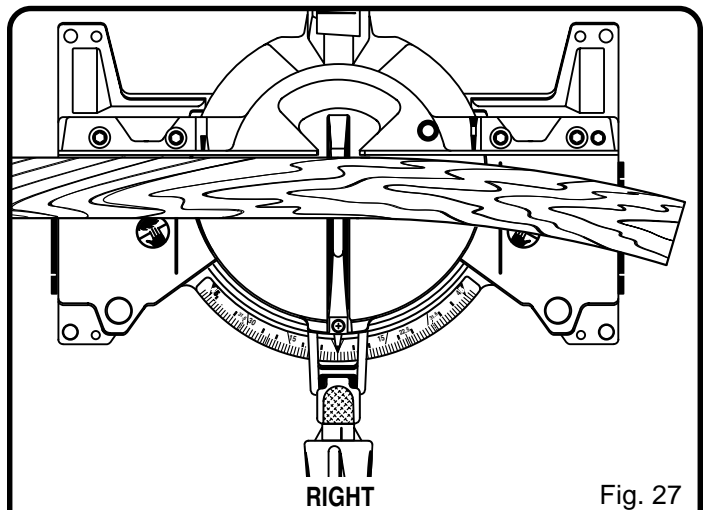

Fig. 27

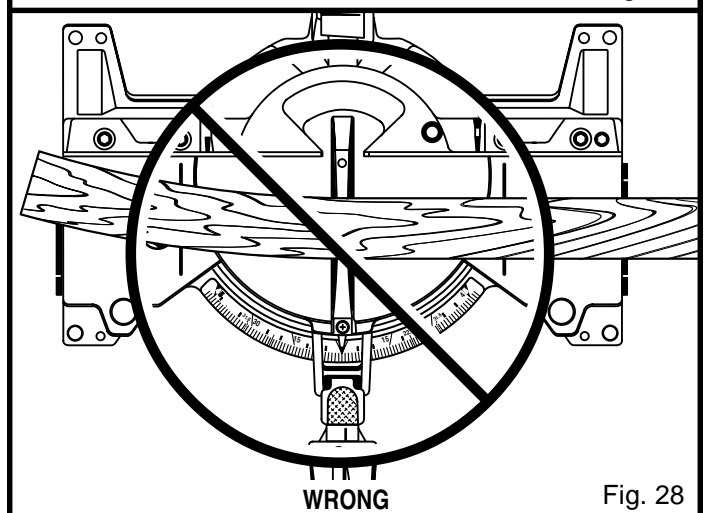

Fig. 28

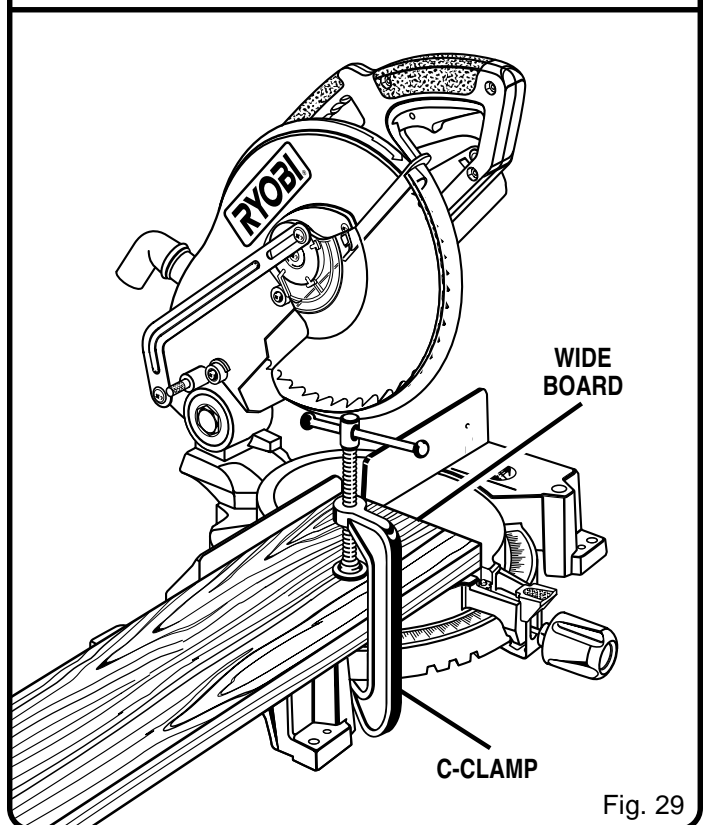

Fig. 29

# MAINTENANCE



## WARNING:

When servicing, use only identical Ryobi replacement parts. Use of any other part may create a hazard or cause product damage.

## GENERAL

Avoid using solvents when cleaning plastic parts. Most plastics are susceptible to damage from various types of commercial solvents and may be damaged by their use. Use clean cloths to remove dirt, carbon dust, etc.



## WARNING:

Do not at any time let brake fluids, gasoline, petroleum-based products, penetrating oils, etc. come in contact with plastic parts. They contain chemicals that can damage, weaken or destroy plastic.

It has been found that electric tools are subject to accelerated wear and possible premature failure when they are used on fiberglass, wallboard, spackling compounds, or plaster. The chips and grindings from these materials are highly abrasive to electric tool parts such as bearings, brushes, commutators, etc. Consequently, it is not recommended that this tool be used for work on any fiberglass material, wallboard, spackling compounds, or plaster. Wood and plastic are the only recommended materials to be cut with this saw. When cutting these materials it is extremely important that the tool is cleaned frequently by blowing with an air jet.

## LUBRICATION

All of the bearings in this tool are lubricated with a sufficient amount of high grade lubricant for the life of the unit under normal operating conditions. Therefore, no further lubrication is required.

## EXTENSION CORDS

The use of any extension cord will cause some loss of power. To keep the loss to a minimum and to prevent tool overheating, use an extension cord that is heavy enough to carry the current the tool will draw.

A wire gage size (A.W.G.) of at least **14** is recommended for an extension cord 25 feet or less in length. When working outdoors, use an extension cord that is suitable for outdoor use. The cord's jacket will be marked WA.



## CAUTION:

Keep extension cords away from the cutting area and position the cord so that it will not get caught on lumber, tools, etc., during cutting operation.



## WARNING:

Check extension cords before each use. If damaged, replace immediately. Never use tool with a damaged cord since touching the damaged area could cause electrical shock resulting in serious injury.



## WARNING:

Always wear safety goggles or safety glasses with side shields during power tool operation or when blowing dust. If operation is dusty, also wear a dust mask.

# MAINTENANCE

## WARNING:

To ensure safety and reliability, all repairs — with the exception of the externally accessible brushes — should be performed by a qualified service technician at a **Ryobi Authorized Service Center** to avoid risk of personal injury.

## BRUSH REPLACEMENT

See Figure 30.

Your saw has externally accessible brush assemblies that should be periodically checked for wear.

**Proceed as follows when replacement is required:**

- Unplug your saw.

## WARNING:

Failure to unplug your saw could result in accidental starting causing serious injury.

- Remove brush cap with a screwdriver. Brush assembly is spring loaded and will pop out when you remove brush cap.
- Remove brush assembly.
- Check for wear. Replace both brushes when either has less than 1/4 in. length of carbon remaining. **Do not** replace one side without replacing the other.
- Reassemble using new brush assemblies. Make sure curvature of brush matches curvature of motor and that brush moves freely in brush tube.
- Make sure brush cap is oriented correctly (straight) and replace.
- Tighten brush cap securely. **Do not** overtighten.

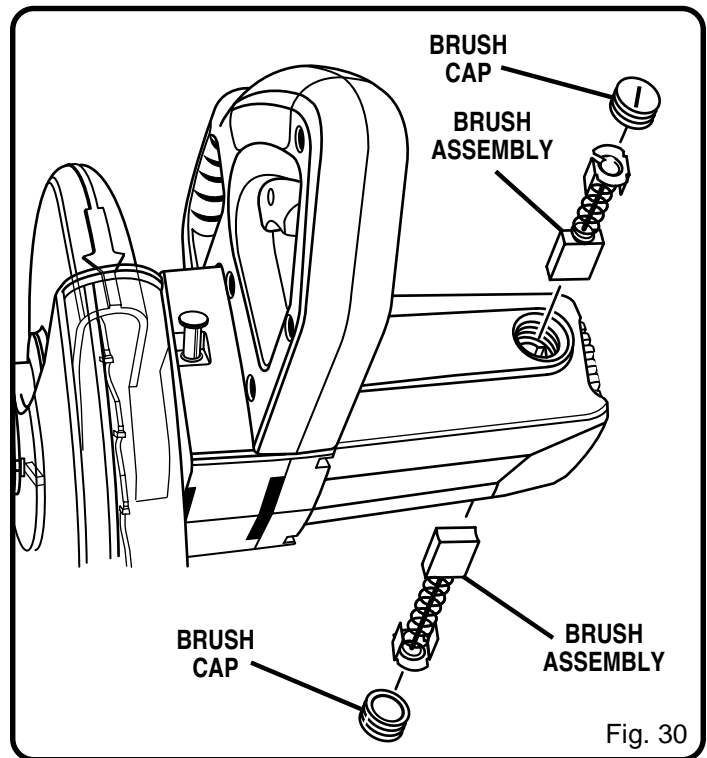

# TROUBLESHOOTING

PROBLEM	CAUSE	SOLUTION
Saw will not start.	<ol style="list-style-type: none"> <li>1. Saw not plugged in.</li> <li>2. Faulty switch.</li> <li>3. Fuse blown or circuit breaker tripped.</li> <li>4. Cord damaged.</li> <li>5. Worn, broken brushes.</li> </ol>	<ol style="list-style-type: none"> <li>1. Plug in saw.</li> <li>2. Have switch replaced by an Authorized Service Center.</li> <li>3. Replace fuse or reset circuit breaker.</li> <li>4. Have cord replaced by an Authorized Service Center.</li> <li>5. Replace brushes.</li> </ol>
Saw makes unsatisfactory cuts.	<ol style="list-style-type: none"> <li>1. Dull blade.</li> <li>2. Blade mounted backwards.</li> <li>3. Gum or pitch on blade.</li> <li>4. Incorrect blade for work being done.</li> </ol>	<ol style="list-style-type: none"> <li>1. Replace blade.</li> <li>2. Turn blade around.</li> <li>3. Remove blade and clean with turpentine and coarse steel wool.</li> <li>4. Change the blade.</li> </ol>
Blade does not come up to speed.	<ol style="list-style-type: none"> <li>1. Extension cord too light or too long.</li> <li>2. Low supply voltage.</li> </ol>	<ol style="list-style-type: none"> <li>1. Replace with the adequate size extension cord.</li> <li>2. Contact the electric company.</li> </ol>
Saw vibrates excessively.	<ol style="list-style-type: none"> <li>1. Blade bolt not tight.</li> <li>2. Saw not mounted securely to workbench.</li> <li>3. Workbench on uneven floor.</li> <li>4. Blade or blade flanges not clean.</li> </ol>	<ol style="list-style-type: none"> <li>1. Tighten blade bolt.</li> <li>2. Tighten all mounting hardware.</li> <li>3. Reposition workbench on flat surface. Fasten workbench to floor if necessary.</li> <li>4. Clean blade and blade flanges.</li> </ol>
Does not make accurate 45° and 90° cuts.	<ol style="list-style-type: none"> <li>1. Damaged saw blade.</li> <li>2. Positive stop not adjusted correctly.</li> </ol>	<ol style="list-style-type: none"> <li>1. Replace blade.</li> <li>2. Check and adjust positive stop.</li> </ol>
Material pinches blade.	<ol style="list-style-type: none"> <li>1. Cutting bowed material in wrong position.</li> </ol>	<ol style="list-style-type: none"> <li>1. Position bowed material correctly (convex side to the back fence).</li> </ol>
Saw head does not return to UP position.	<ol style="list-style-type: none"> <li>1. No spring tension.</li> <li>2. Spring broken.</li> </ol>	<ol style="list-style-type: none"> <li>1. Return to an Authorized Service Center for adjustment.</li> <li>2. Have spring replaced by an Authorized Service Center.</li> </ol>

# RYOBI<sup>®</sup> OPERATOR'S MANUAL

## 10 in. (254 mm) Miter Saw

### Model TS1301

#### EXTENSION CORD CAUTION

When using a power tool at a considerable distance from a power source, be sure to use an extension cord that has the capacity to handle the current the tool will draw. An undersized cord will cause a drop in line voltage, resulting in overheating and loss of power. Use the chart to determine the minimum wire size required in an extension cord. Only round jacketed cords should be used.

When working with a tool outdoors, use an extension cord that is designed for outside use. This is indicated by the letters "WA" on the cord's jacket.

Before using any extension cord, inspect it for loose or exposed wires and cut or worn insulation.

\*\*Ampere rating

(on tool data plate) 0-2.0    2.1-3.4    3.5-5.0    5.1-7.0    7.1-12.0    12.1-16.0

Cord Length	Wire Size (A.W.G.)					
25'	16	16	16	16	14	14
50'	16	16	16	14	14	12

 **CAUTION:** Keep the extension cord clear of the working area. Position the cord so that it will not get caught on workpiece, tools, or other obstructions while you are working with a power tool.

*\*\*Used on 12 gauge - 20 amp circuit.*

#### • SERVICE

Now that you have purchased your tool, should a need ever exist for repair parts or service, simply contact your nearest Ryobi Authorized Service Center. Be sure to provide all pertinent facts when you call or visit. Please call 1-800-525-2579 for your nearest Ryobi Authorized Service Center. You can also check our web site at [www.ryobitools.com](http://www.ryobitools.com) for a complete list of Authorized Service Centers.

#### • MODEL NO.

The model and serial numbers of your tool will be found on a plate attached to the motor housing. Please record the serial number in the space provided below.

- MODEL NUMBER \_\_\_\_\_ TS1301 \_\_\_\_\_
- SERIAL NUMBER \_\_\_\_\_

#### RYOBI TECHNOLOGIES, INC.

1428 Pearman Dairy Road Anderson SC 29625  
 Post Office Box 1207 Anderson SC 29622-1207  
 Phone 1-800-525-2579  
[www.ryobitools.com](http://www.ryobitools.com)